

Professional Training Equipment for Professional Customers

Competencies & Products -
in a Nutshell



東方科技公司

ORIENTAL TECHNOLOGY COMPANY

Wholly Owned By ORIENTAL TECH DEVELOPMENT LTD.

香港九龍荔枝角青山道 688-690 號 嘉名工廠大廈 4 樓 E 座
BLOCK E, 4/F., KA MING COURT, 688-690 CASTLE PEAK ROAD
LAI CHI KOK, KOWLOON, H.K. Tel: (852) 24023200 Fax: 24133100
Web Site: www.otdl.com Email: info@otdl.com

Cockpitsonic

- Your most-innovative Supplier of civil Flight Training Devices
 - Best-in-Class Price-to-Performance Ratio
 - Maximum utilization of COTS technologies
 - Certifiable to international Qualification Standards
 - Reliable and durable – at lowest life-cycle-costs
- Specialized in civil Flight Training Applications
 - From most-efficient Table-Top Trainers to certified Full-Motion-Simulators
 - Fixed Wing and Rotary Wing solutions
- All-In-One System Supplier with full-scope In-House capabilities
 - Full System Integration capabilities
 - Visual and 6-DoF Integration competence
 - Own in-house Production Line
 - Comprehensive After-Sales-Support packages
- Global footprint, significant existing customer base
- Your Simulator-Hardware Power-Partner of Choice
 - compliant & professional
 - risk sharing & responsible
 - independent & objective
- Specialized in Military High-End Applications
- All-In-One System Supplier for Pre-Integrated Capabilities
- Over 3 decades of experience in the field of simulation technology and system integration
- Complete in-house design and production capacity including
 - Mechanical Engineering and CAD-design
 - Electronics Engineering, Design and Development
 - Software/Firmware Development
 - CNC machining
 - Paint Shop and Laser Inscribing
 - Professional assembly and testing



OSIMCO SYSTEMS

- Your Simulator-Hardware Power-Partner of Choice
 - compliant & professional
 - risk sharing & responsible
 - independent & objective
- Specialized in Military High-End Applications
- All-In-One System Supplier for Pre-Integrated Capabilities
- Over 3 decades of experience in the field of simulation technology and system integration
- Complete in-house design and production capacity including
 - Mechanical Engineering and CAD-design
 - Electronics Engineering, Design and Development
 - Software/Firmware Development
 - CNC machining
 - Paint Shop and Laser Inscribing
 - Professional assembly and testing

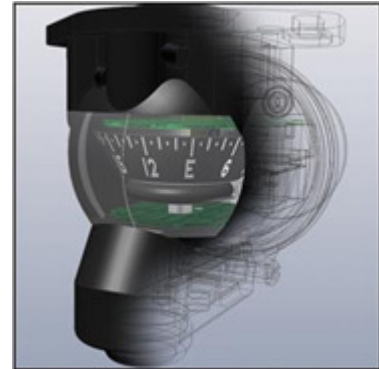

OSIMCO SYSTEMS

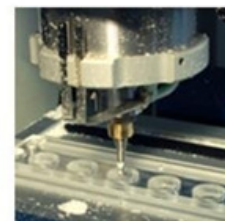
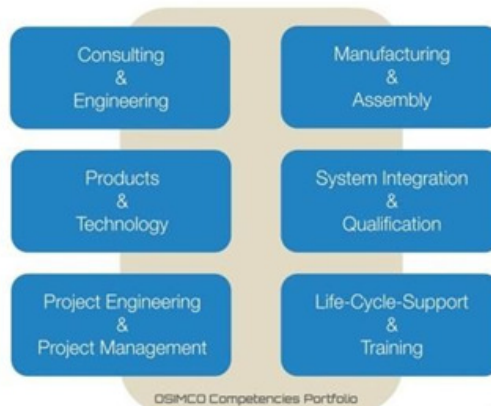
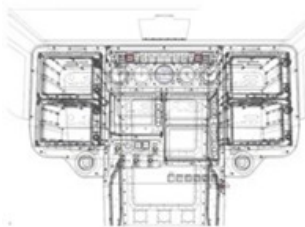

JOINING FORCES

- Benefit from both companies joining forces
 - benefit from our large expertise in the designing and manufacturing of a wide range of cockpit types from budget & commercial entertainment, FTP, APT, ICAO L6, ICAO L7 for military and civil aircrafts
 - Reliable contacts and sources of technical information and access to quality and certified suppliers
 - Experience meeting the requirements and standards of military projects, including NVIS compatibility
 - Competence for building High Fidelity Training Solutions suitable for Full-Flight-Simulators
- Additional benefits and synergies
 - Complete in-house design and production including electronics development
 - Standard CANopen interface - all hardware in our training systems is in compliance with the requirements of the guidelines and international standards of the nonprofit CiA (CAN in Automation) organization
 - Type specific level of fidelity - true replicas in terms of form, feel and function
 - Spare Parts - industrial standard components helps to ensure the provision of spare parts for years to come



THE VALUES WE SHARE

Customer Focus: We live for our customers' mission readiness and aim to make their everyday life easier

- **Responsibility and Accountability:** We build long-term value partnerships not just one-time business transactions
- **Fairness:** We provide fair and objective technical and commercial assessment by finding appropriate and targeted solutions
- **Openness and Service:** We believe that an open communication, a fair technical and engineering assessment, engaged project management, and a personalized customer service are essential for a successful and long lasting partnership
- **Innovation Spirit:** We have a proactive attitude, always looking for clever solutions, innovation and alternative concepts and technologies
- **Quality:** We deliver high-end results through efficiency, reliability, compliance, customized and targeted solutions, attention to detail, high-grade materials, innovative design, first rate Life-cycle Services and Integrated Logistic Support

AMST B-737

- Project example - B-737 Simulator ICAO Level 6

About Cockpitsonic's Partner AMST

The complex field of technology combines different disciplines to a complete solution. Knowing each level and detail, we are able to provide the optimal solution

AMST is a think tank, in other words a centre of excellence dedicated to research, innovation, design and manufacturing of equipment in the very specialised areas of Aeromedicine and Aircrew Training.

AMST has a discerning clientele who share the conviction that second best is not good enough. That is why those who seek to enhance their operational capabilities choose AMST's superior, proven technology.



WM Simulator A320

- Project example – A320 Simulator FSTD Type VI

About Cockpitsonic's Partner WM SIMULATOR

WM SIMULATOR Company Limited is a developer and provider of systems design, procurement, installation and counseling, as well as maintenance.

Integrated first in Thailand is committed to developing and providing the flight training simulator has been certified by the Civil Aviation Organization, the set is dedicated to the service. maximum benefit. By providing quality products, best practices for aviation personnel. To create an effective staff.



SELECTED REFERENCES: Helicopted

- **Osimco's Helicopter Reference List**

- EC135 FFS (8 Units) German Army, Bückebug
- EC135 FNPT II/ FTD 3/MCC Finnish Aviation Academy
- EC135 FNPT III/JAR FTD H FTD2 German National Police, Bonn
- EC135 B JAR-FSTD H Level A ADAC, Bonn-Hangelar
- EC145 B JAR-FSTD H Level A ADAC, Bonn-Hangelar
- EC135 FTD Level 3 MCC LPR, Warsaw
- EC135 FFS Level C: Airbus Helicopters Japan, Kobe
- EC635 FNPT (Motion) Iraqi Air Force
- AS350 Level B FFS/Mission Trainer Airbus Helicopters USA, Dallas
- EC225 AA FFS Level B and JAA FTD 3 Bristow, Aberdeen
- AS332 L2 (Super Puma) CHC Helicopter, Aberdeen
- EC135/145 Airbus Helicopters USA, Dallas/Grand Prairie
- AW 159 (Wildcat) FFS Level D,(Full Mission)(2 Units) RNAS Yeovilton
- AW 159 (Wildcat) FTD Royal Navy/British Army, RNAS Yeovilton
- AW 159 (Wildcat) CPT Royal Navy/British Army, RNAS Yeovilton
- CH-53GS FFS Upgrade (2 units) German Army, Bückebug
- CH-53GA CPT (4 Units) German Army, Holzdorf, Laupheim
- CH-53GA MT (2 Units) German Army
- CH-53GA FFS (2 Units) German Army, Bückebug
- EC155 FNPT German National Police, Bonn-Hangelar
- AS332 (Super Puma) FNPT German National Police, Bonn-Hangelar
- EC135 FFS Level D (1 unit), FMS (1 unit) Spanish Army (FAMET)
- Sea King Mk41 German Navy, Nordholz
- NH 90
- EC145T2
- UH-72A S&S Battalion, Slick/Medevac



Customers we serve



indra

THALES

